

Introduction

This publication is part of a series of three guides entitled *How to design masonry structures using Eurocode 6*. The aim is to make the use of Eurocode 6, *Design of masonry structures* as easy as possible by drawing together in one place key information and commentary required for the design of typical masonry elements.

The Concrete Centre (and, originally, The Modern Masonry Alliance) recognised that effective guidance was required to ensure that the UK design profession was able to use Eurocode 6 quickly, effectively, efficiently and with confidence. Therefore a steering group, with members from across the masonry industry (see back cover for a list of members), was established to oversee the development and publication of the original guides.

This second revision addresses the publication of PD6697 in 2010 and revised National Annex to BS EN 1996-1-1 in 2013. It was overseen by a reconstituted steering group from industry (see back cover).



Guidance for vertical resistance

This guide is the second in a series of three giving guidance on the design of masonry structures to Eurocode 6¹. The first guide, *Introduction to Eurocode 6*² gives an introduction to design and assessment of actions using Eurocode 6 and also covers the specification and execution (workmanship) of masonry. This guide explains how to design for vertical actions and determine vertical resistance. The third guide in the series³ covers the design of laterally loaded masonry panels. Throughout this guide the Nationally Determined Parameters (NDPs) from the UK National Annexes (NAs) have been used. These enable Eurocode 6 to be applied in the UK.

Design procedure

This guide explains how to determine the design resistance for a vertically loaded wall. The first guide in the series, *Introduction to Eurocode 6*, should be referred to so that the design load can be determined. In essence, when using the Eurocodes the designer should check that the resistance is greater than or equal to the effect of the actions. A flow chart for the design of masonry walls to resist vertical actions is shown as Figure 1.

Compressive strength

Eurocode 6 introduces some new concepts when dealing with the design of masonry for vertical loads. The first of these relates to the way the compressive strength of the masonry units is expressed. For design purposes the normalized compressive strength, $f_{k,p}$, of the masonry units is used. This is the compressive strength of the units converted to the air-dried compressive strength of an equivalent 100 mm wide by 100 mm high masonry unit. The detail is contained in Part 1 of BS EN 772, *Methods of test for masonry units*⁴. The advantage to the designer is that the normalized strength is independent of the size and shape of the units used in the final construction.

Grouping of masonry units

The second change relates to the way in which masonry units are classified. This is dealt with by grouping masonry into one of four groups as shown in Table 3.1 of Eurocode 6. The group designation will normally be declared by the manufacturer. The designation depends upon the volume and direction of holes in the unit and the thickness of webs and shells. Historically only Group 1 and Group 2 units have been used in the UK, so only values for these groups are given in the UK NAs.

The characteristic compressive strength of masonry

The characteristic compressive strength of masonry (other than shell bedded masonry) is determined from the results of tests in accordance with BS EN 1052-1⁵. The tests are carried out on small wallette specimens rather than the storey-height panels used in the past. The designer has the option of either testing the units intended to be used in a project or using the values determined from a database. Values from a large database are provided in the UK NA to Eurocode 6, Part 1-1 in the form of the constants to be used in the following equation:

$$f_k = K f_b^\alpha f_m^\beta \quad \text{[Equation (3.1) of Eurocode 6, Part 1-1]}$$

where

- f_k = characteristic compressive strength of the masonry, in N/mm²
- K = constant – see Table 1 and Figure 2
- α, β = constants – see Table 2
- f_b = normalized mean compressive strength of the units, in the direction of the applied action effect, in N/mm²
- f_m = compressive strength of the mortar, in N/mm²

For blocks laid flat, Table 8 of the National Annex to Eurocode 6, Part 1-1 contains a specific value for K to be used in Equation (3.1) of Eurocode 6, Part 1-1.

The following limitations are placed on Equation (3.1):

- The masonry is detailed and constructed in accordance with the requirements of BS EN 1996-1-1, section 8.
- f_b is taken to be not greater than 110 N/mm² when units are laid in general purpose mortar and 50 N/mm² when laid in thin layer mortar (f_b is determined in the normal direction of loading).
- f_m is taken to be not greater than f_b nor greater than 12 N/mm² when units are laid in general purpose mortar or 10 N/mm² when units are laid in lightweight mortar.
- The coefficient of variation of the strength of the masonry unit is not more than 25%.

For masonry made with general purpose mortar, adjustments are made to the value of K as shown in Figure 2.

In addition the following points should be noted:

- For masonry made of general purpose mortar where Group 2 and Group 3 aggregate concrete units are used with the vertical cavities filled completely with concrete, the value of f_b should be obtained by considering the units to be Group 1 having a compressive strength corresponding to the compressive strength of the units or of the concrete infill, whichever is the lesser.

Figure 1
Flow chart for the design of masonry walls to resist vertical actions

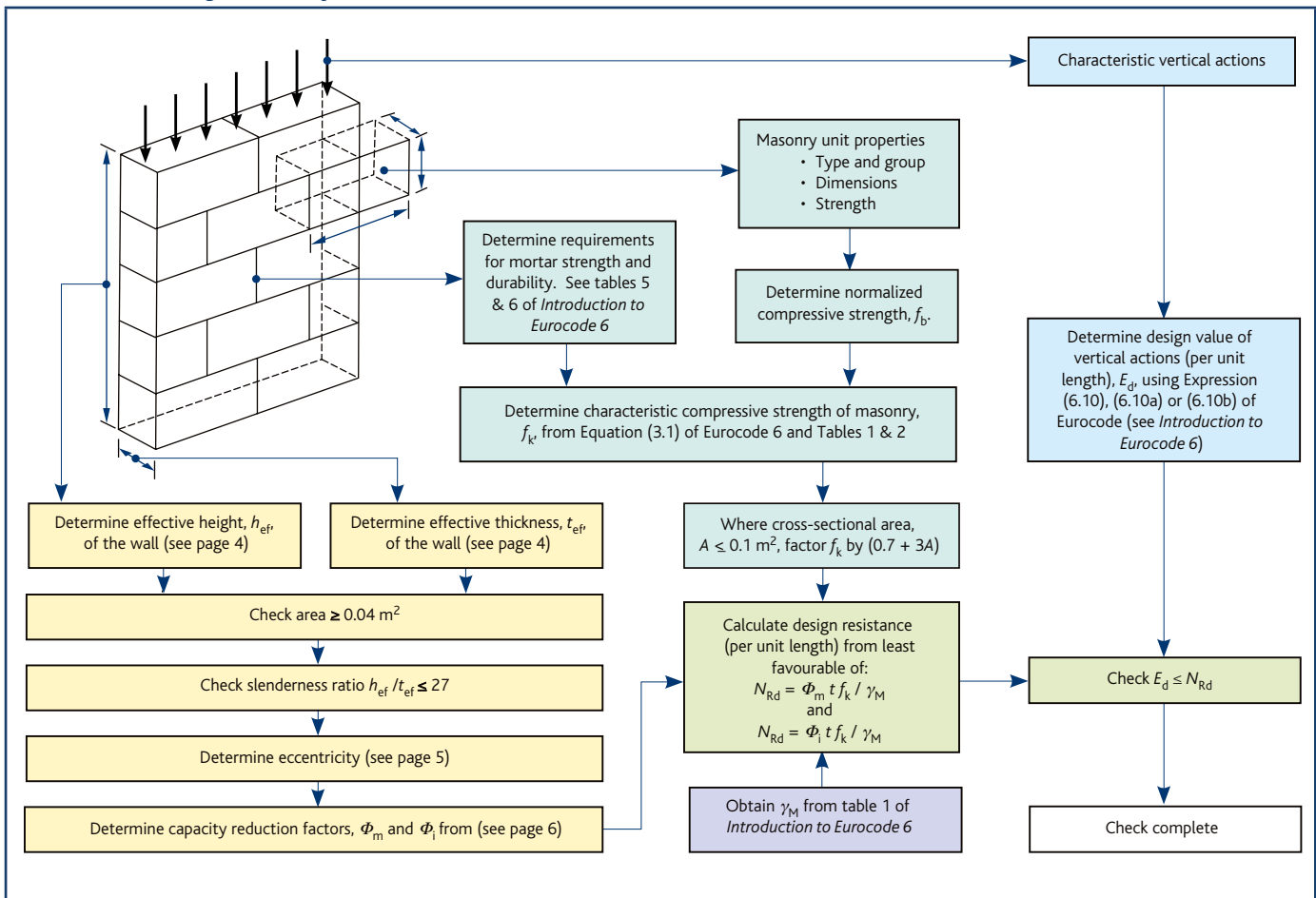

- For collar jointed aggregate concrete masonry made with general purpose mortar, with or without the collar filled with mortar, the unit shape factor correction to obtain the normalized strength should use the width of the wall as the unit width and the height of the masonry units.
- Where action effects are parallel to the direction of the bed joints, the characteristic compressive strength may be determined from Equation (3.1) with f_b derived from BS EN 772–1, where the direction of application of the load to the test specimens is in the same direction as the direction of the action effect in the masonry, but with the shape factor, δ , as given in BS EN 772–1 taken to be no greater than 1.0. For Group 2 and 3 units, K should then be multiplied by 0.5.

Table 1
Values of K to be used with equation (3.1)

Masonry unit	General purpose mortar	Thin layer mortar (bed joint ≥ 0.5 mm and ≤ 3 mm)	Lightweight mortar of density (kg/m^3)	
			$600 \leq \rho_d \leq 800$	$800 < \rho_d \leq 1300$
Clay				
Group 1	0.50	0.75	0.30	0.40
Group 2	0.40	0.70	0.25	0.30
Group 3 and 4	– a	– a	– a	– a
Calcium silicate				
Group 1	0.50	0.80	– b	– b
Group 2	0.40	0.70	– b	– b
Aggregate concrete				
Group 1	0.75	0.90	0.45	0.45
Group 1 ^c (units laid flat)	0.50 ^d	0.70 ^d	0.40 ^d	0.40 ^d
Group 2	0.70	0.76	0.45	0.45
Group 3 and 4	– a	– a	– a	– a
Autoclaved aerated concrete				
Group 1	0.75	0.90	0.45	0.45
Manufactured stone				
Group 1	0.75	0.90	– b	– b
Dimensioned natural stone				
Group 1	0.45	– b	– b	– b

Key

- a Group 3 and 4 units have not traditionally been used in the UK, so no values are available.
- b These masonry unit and mortar combinations have not traditionally been used in the UK, so no values are available.
- c If Group 1 aggregate concrete units contain formed vertical voids in the normal direction, multiply K by $(100 - n) / 100$, where n is the percentage of voids, maximum 25%.
- d When aggregate concrete masonry units are to be used laid flat the normalised strength of the unit should be calculated using the width and height of the unit in the upright position along with the compressive strength of the unit tested in the upright position.

Note
Where a mortar joint is parallel to the face of the wall K should be modified (see Figure 2)

Table 2
Values to be used in Equation (3.1)

Type of mortar	Values to be used
General purpose mortar	$\alpha = 0.7$ and $\beta = 0.3$
Lightweight mortar	$\alpha = 0.7$ and $\beta = 0.3$
Thin layer mortar in bed joints of thickness 0.5 to 3 mm (using clay units of Group 1, calcium silicate units, aggregate concrete units and autoclaved aerated concrete units)	$\alpha = 0.85$ and $\beta = 0$
Thin layer mortar in bed joints of thickness 0.5 to 3 mm (using clay units of Group 2)	$\alpha = 0.7$ and $\beta = 0$

- When the perpendicular joints are unfilled, Equation (3.1) may be used, with consideration of any horizontal actions that might be applied to, or be transmitted by, the masonry. (See also Cl. 3.6.2(4) of BS EN 1996–1–1.)

The characteristic compressive strength of shell bedded masonry

Shell bedding provides two strips of mortar rather than a full mortar bed. It serves to improve rain penetration resistance but reduces the strength of the masonry. A typical shell bedded unit is shown in Figure 3.

For Group 1 and Group 4 units the procedure above may be used to obtain the characteristic compressive strength of the masonry.

Figure 2
Modifications to K for units laid with general purpose mortar

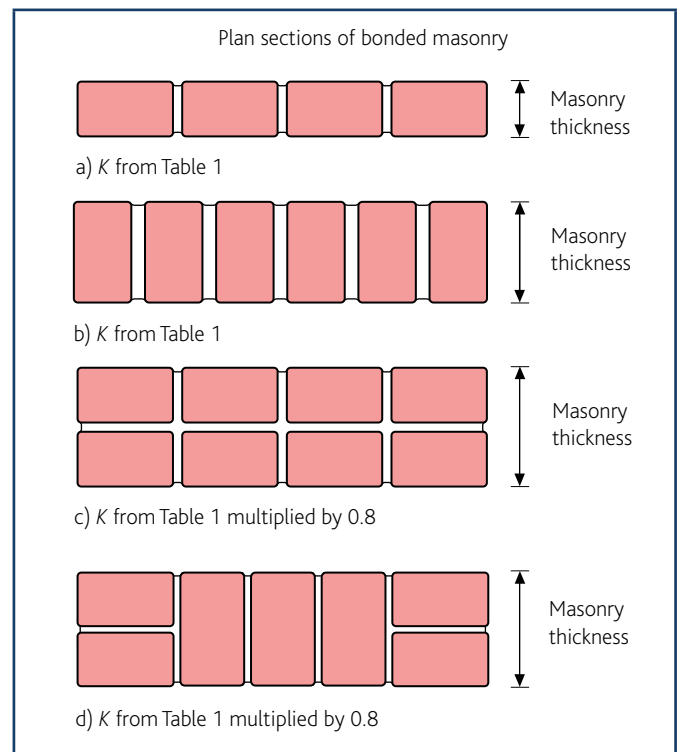
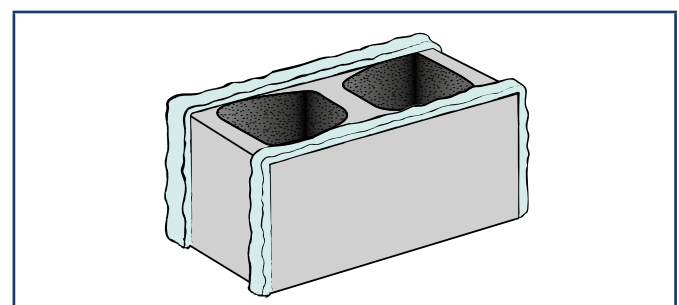

Figure 3
Shell bedding



provided that:

- The width of each strip of mortar is at least 30 mm.
- The thickness of the masonry wall is equal to the width or length of the masonry units so that there is no longitudinal mortar joint through all or part of the length of the wall.
- The ratio g/t is not less than 0.4 where
 - g = total width of the mortar strips
 - t = the thickness of the wall.
- K is taken as above when $g/t = 1.0$ or half this value when $g/t = 0.4$. Linear interpolation may be used for intermediate values.

Groups 2 and 3 may be designed as non-shell bedded masonry provided that the normalized mean compressive strength of the units used in Equation (3.1) is obtained from tests carried out in accordance with BS EN 772-1⁴ for shell bedded units.

Effective height

The effective height of a masonry wall is obtained by applying a factor to the clear height of the wall such that:

$$h_{ef} = \rho_n h$$

where

- h_{ef} = effective height of the wall
- h = clear storey height of the wall
- ρ_n = reduction factor, where $n = 2, 3$ or 4 , depending upon the edge restraint or stiffening of the wall

The reduction factor to be applied depends upon the restraint offered by adjoining elements. Masonry walls may be stiffened by a number of rigid structural elements such as floors, roofs and other walls. Stiffening walls should have a length of at least 1/5 of the clear height

Figure 4
Minimum length of stiffening wall with openings

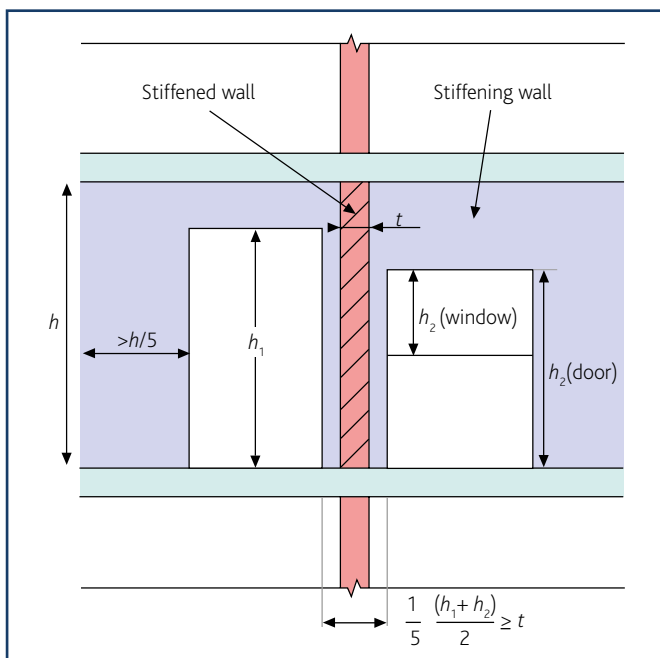

and have a thickness of at least 0.3 times the effective thickness of the wall to be stiffened. When the stiffening wall contains openings, the minimum length of wall should be as shown in Figure 4 and the stiffening wall should extend a distance of at least 1/5 of the storey height beyond each opening.

Where a wall is restrained at the top and bottom by reinforced concrete floors or roofs spanning from both sides at the same level or by a reinforced concrete floor spanning from one side only and having a bearing of at least 2/3 of the thickness of the wall then:

$$\rho_2 = 0.75$$

unless the eccentricity of the load at the top of the wall is greater than 0.25 times the thickness of the wall, in which case $\rho_2 = 1.0$.

Where the wall is restrained by timber floors or roofs spanning from both sides at the same level or by a timber floor spanning from one side having a bearing of at least 2/3 the thickness of the wall but not less than 85 mm, then:

$$\rho_2 = 1.0.$$

For walls restrained at the top and bottom and stiffened on one vertical edge, use ρ_n = the value ρ_3 from Figure 5 and where both vertical edges are stiffened, use ρ_n = the value ρ_4 from Figure 6. Note that Equations (5.6), (5.7) and (5.8) in Eurocode 6, Part 1-1 may be used as an alternative to the use of the graphs.

Effective thickness

For a single-leaf wall, a double-leaf wall (with ties at a density of 2.5 per m² or greater), a faced wall, a shell bedded wall and a grouted cavity wall, the effective thickness, t_{ef} , is taken as the actual thickness

Figure 5
Graph showing values of ρ_3

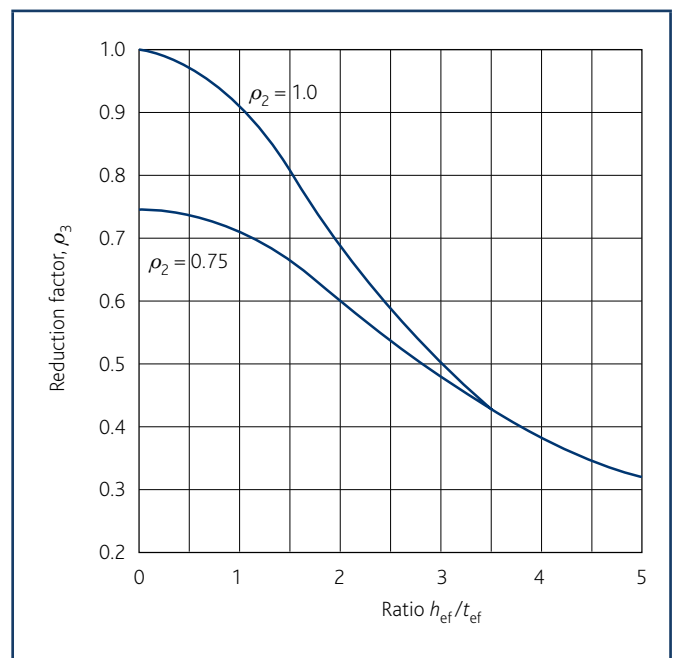

of the wall (t), provided this is greater than the minimum thickness, t_{\min} . The value of t_{\min} for a loadbearing wall should be taken as 90 mm for a single-leaf wall and 75 mm for the leaves of a cavity wall.

For a cavity wall the effective thickness is determined using the following equation:

$$t_{\text{ef}} = \sqrt[3]{t_1^3 + t_2^3} \geq t_2$$

where

t_1 = actual thickness of the outer or unloaded leaf

t_2 = actual thickness of the inner or loaded leaf

Note that the effective thickness of the unloaded leaf should not be taken to be greater than the thickness of the loaded leaf and that ties should be provided at a density of 2.5 per m^2 or greater.

When a wall is stiffened by piers the effective thickness is enhanced by using the following equation:

$$t_{\text{ef}} = \rho_t t$$

where

t_{ef} = effective thickness

ρ_t = coefficient obtained from Table 3

t = thickness of the wall

Slenderness ratio

The slenderness ratio of the wall is obtained by dividing the effective height by the effective thickness and should not be greater than 27 for walls subjected to mainly vertical loading. Note also that the effects of creep may be ignored in walls with a slenderness ratio up to 27.

Figure 6
Graph showing values of the reduction factor, ρ_4

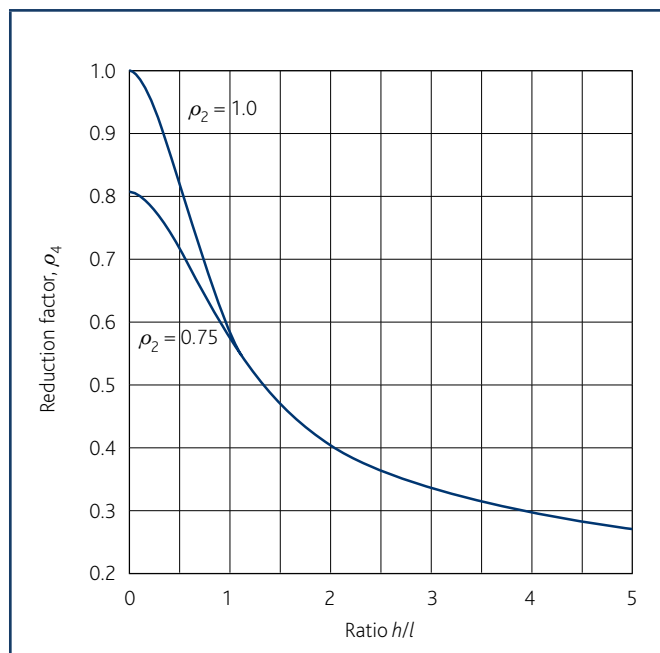

Assessment of eccentricity

When a wall is subjected to actions that result in an eccentricity at right angles to the wall, Eurocode 6 requires the resistance of the wall to be checked at the top, mid-height and bottom. The eccentricity at top or bottom of the wall is:

$$e_i = \frac{M_{id}}{N_{id}} + e_{he} + e_{init} \geq 0.05t$$

where

M_{id} = design value of the bending moment at the top or the bottom of the wall resulting from eccentricity of the floor load at the support

N_{id} = design value of the vertical load at the top or the bottom of the wall

e_{he} = the eccentricity at the top or bottom of the wall resulting from the horizontal loads

e_{init} = initial eccentricity for construction imperfections, which may be taken as $h_{ef}/450$, with a sign that increases the absolute value of e_i and e_m as appropriate

t = thickness of the wall

The mid-height eccentricity, e_{mk} , is:

$$e_{mk} = e_m + e_k \geq 0.05t$$

where

$$e_m = \frac{M_{md}}{N_{md}} + e_{hm} + e_{init}$$

$e_k = 0$, when the slenderness ratio ≤ 27 (ie. ignoring creep)

M_{md} = design value of the greatest moment at the mid-height of the wall resulting from the moments at the top and bottom of the wall, including any load applied eccentrically to the face of the wall (see Figure 7)

N_{md} = design value of the vertical load at the mid-height of the wall, including any load applied eccentrically to the face of the wall

e_{hm} = the eccentricity at mid-height resulting from horizontal loads

A sub-frame analysis may be used as a simplified method for obtaining the moments at the top and bottom of vertically loaded walls, as given in Annex C in Part 1–1 of Eurocode 6.

Table 3
Stiffness coefficient, ρ_t , for walls stiffened by piers

Ratio of pier spacing (centre to centre) to pier width	Ratio of pier thickness to actual thickness of wall to which it is bonded		
	1	2	3
6	1.0	1.4	2.0
10	1.0	1.2	1.4
20	1.0	1.0	1.0

Note

Linear interpolation is permitted in this Table.

Capacity reduction factors

At the top or bottom of the wall, the reduction factor for slenderness and eccentricity is given by:

$$\Phi_i = 1 - 2 \frac{e_i}{t}$$

where

- Φ_i = reduction factor at the top or bottom of the wall
- e_i = eccentricity at the top or bottom of the wall
- t = thickness of the wall

A method for calculating a capacity reduction factor at the mid-height of the wall, Φ_m , is given in Annex G of Eurocode 6, Part 1-1, which simplifies the principles given in CL 6.1.1. This is shown graphically in Figure 8, which shows the corresponding capacity reduction factors for different values of slenderness and eccentricity for an elastic modulus $1000 f_k$, which is the value recommended in the UK NA.

The least favourable value of Φ_i and Φ_m should be used to calculate N_{Rd} .

Vertical load resistance of solid walls and columns

The design resistance of a single-leaf wall per unit length, N_{Rd} , is given by the following:

$$N_{Rd} = \Phi t f_d$$

where

- Φ = capacity reduction factor allowing for the effects of slenderness and eccentricity of loading

Figure 7
Moments from calculation of eccentricities

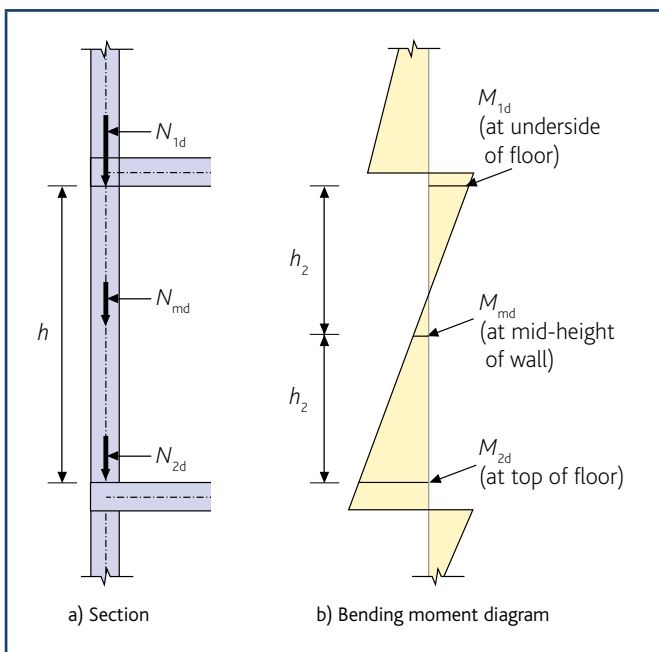

- t = thickness of the wall
- f_d = design compressive strength of the masonry (f_k/γ_M)

For sections of small plan area, less than 0.1 m^2 , f_d should be multiplied by $(0.7 + 3A)$

where

$$A = \text{loadbearing horizontal cross-sectional area of the wall in m}^2$$

In the case of a faced wall, the wall may be designed as a single-leaf wall constructed entirely of the weaker material with a longitudinal joint between leaves.

A double-leaf (collar-jointed) wall may also be designed as for a single-leaf wall provided that the leaves are tied together adequately and both leaves carry similar loads and the cavity does not exceed 25 mm, or it may be designed as a cavity wall with one leaf loaded.

In the case of cavity walls, check each leaf separately using a slenderness ratio based on the effective thickness of the wall.

Concentrated loads

For a Group 1 unit (not shell bedded) the vertical load resistance is:

$$N_{Rdc} = \beta A_b f_d$$

where

$$\beta = \left(1 + 0.3 \frac{a_1}{h_c}\right) \left(1.5 - 1.1 \frac{A_b}{A_{ef}}\right)$$

- = enhancement factor for load that should not be less than 1.0 nor taken to be greater than:
- $1.25 + \frac{a_1}{2h_c}$ or 1.5, whichever is the lesser

Figure 8
Capacity reduction factor, Φ_m at the mid-height of the wall

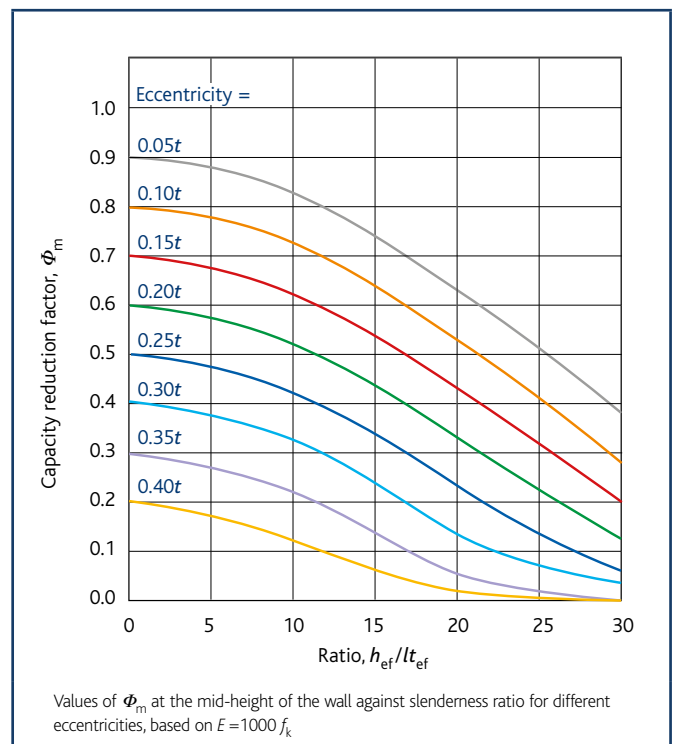

- a_1 = distance from the end of the wall to the nearer edge of the loaded area
- h_c = height of the wall to the level of the load
- A_b = loaded area
- A_{ef} = effective area of the bearing, $l_{efm} t$
- l_{efm} = effective length of the bearing as determined at the mid-height of the wall or pier
- t = thickness of the wall, taking into account the depth of recesses in joints greater than 5 mm wide
- $A_b/A_{ef} \leq 0.45$

The enhancement factor, β , is shown graphically in Figure 9.

For walls built with Groups 2, 3 and 4 masonry units and when shell bedding is used, it is necessary to check that, locally under the bearing of a concentrated load, the design compressive stress does not exceed the design compressive strength of the masonry, f_d (i.e. β is taken to be 1.0).

In any case, the eccentricity of the load from the centre line of the wall should not be greater than $t/4$ as shown in Figure 10.

In all cases where a concentrated load is applied, the requirements for vertical load design should be met at the mid-height of the wall below the bearings. Account should be taken of the effects of any other superimposed vertical loading, particularly where concentrated loads are sufficiently close together for their effective lengths to overlap.

The concentrated load needs to bear on a Group 1 unit or other solid material. The length of this unit or bearing should equal the required bearing length plus a length on each side of the bearing based on a 60° spread of load to the base of the solid material. For an end bearing the extra length is required on one side only.

Figure 9
Enhancement factor, β , concentrated load under bearings

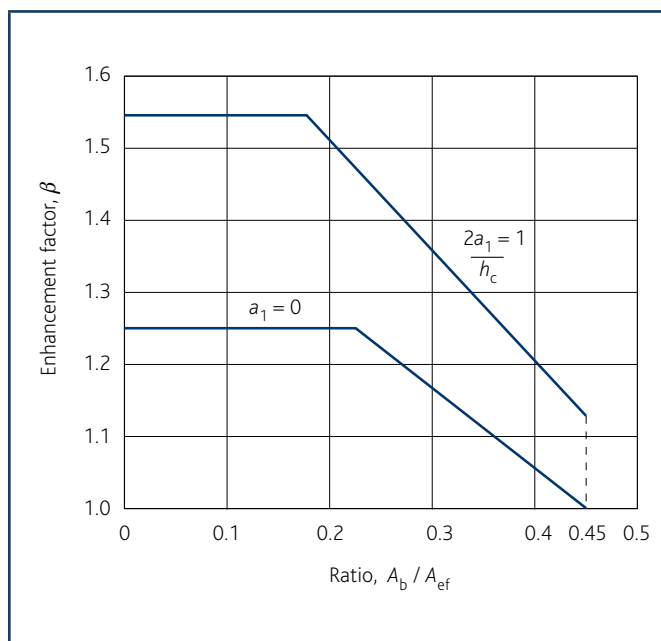

The concentrated load may be applied through a spreader beam of adequate strength and stiffness that has a width the same as the wall thickness, a height greater than 200 mm and a length greater than three times the bearing length of the load. In this case the design value of compressive strength beneath the concentrated load should not exceed $1.5f_d$.

Walls subject to shear forces

The design value of shear resistance is given by:

$$V_{Rd} = f_{vd} t l_c$$

where

- V_{Rd} = the design value of shear resistance of the wall
- f_{vd} = the design value of the shear strength of the masonry (the characteristic shear strength divided by the partial factor for masonry, γ_M) based on the average vertical stresses over the compressed part of the wall that is providing the shear resistance
- t = the thickness of the wall resisting the shear
- l_c = the length of the compressed part of the wall, ignoring any part of the wall that is in tension

In calculating l_c assume a linear distribution of the compressive stress, take into account openings, etc. and do not include any area of the wall subjected to vertical tensile stresses.

Effect of chases

Eurocode 6 recognises that chases and recesses should not impair the stability of a wall and provides appropriate guidance. Further explanation is given in the third guide in this series, *Lateral resistance*³.

Figure 10
Walls subjected to concentrated load

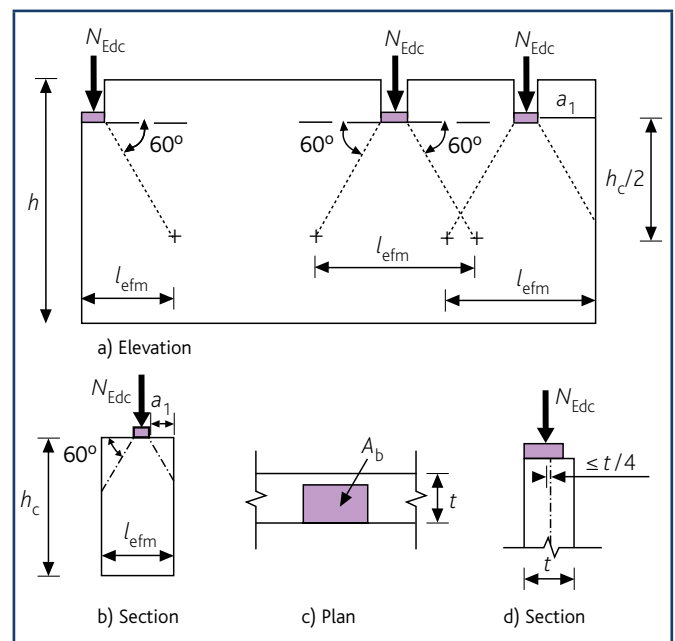

Selected symbols

Symbol	Definition
A	Loadbearing horizontal cross-sectional area of the wall in m^2
a_1	Distance from the end of the wall to the nearer edge of the loaded area
A_b	Loaded area
A_{ef}	Effective area of the bearing
e_{he}	Eccentricity of the top or bottom of the wall resulting from horizontal loads
e_{hm}	Eccentricity at the middle of a wall, resulting from horizontal loads
e_i	Eccentricity of the wall
e_{init}	Initial eccentricity
e_m	Load eccentricity
e_{mk}	Eccentricity at the mid-height of the wall
f_b	Normalized mean compressive strength of a masonry unit
f_d	Design compressive strength of the masonry in the direction being considered
f_m	Compressive strength of the mortar
f_k	Characteristic compressive strength of the masonry, in N/mm^2
f_{vk}	Characteristic shear strength of masonry
f_{vd}	Design value of the shear strength of the masonry
g	Total of the widths of the mortar strips
h	Clear storey height of the wall
h_c	Height of the wall to the level of the load
h_{ef}	Effective height of the wall
h_{tot}	Total height of the structure
K	Constant to be used with Equation (3.1) of Eurocode 6, Part 1–1
l_c	Length of the compressed part of the wall, ignoring any part of the wall that is in tension.

Symbol	Definition
l_{efm}	Effective length of the bearing as determined at the mid-height of the wall or pier
M_{id}	Design value of the bending moment at the top or the bottom of the wall resulting from eccentricity of the floor load at the support
M_{md}	Design value of the greatest moment at the mid-height of the wall resulting from the moments at the top and bottom of the wall, including any load applied eccentrically to the face of the wall
N_{id}	Design value of the vertical load at the top or the bottom of the wall
N_{md}	Design value of the vertical load at the mid-height of the wall, including any load applied eccentrically to the face of the wall
N_{Rd}	Design resistance of a single-leaf wall per unit length
N_{Rdc}	Design vertical load resistance to a concentrated load
t	Thickness of the wall
t_1	Effective thickness of the outer or unloaded leaf
t_2	Effective thickness of the of the inner or loaded leaf
t_{ef}	Effective thickness
t_{min}	Minimum thickness of loadbearing wall
V_{Rd}	Design value of shear resistance of the wall
v	Notional inclination angle to the vertical
α and β	Constants to be used with Equation (3.1) of Eurocode 6, Part 1–1
β	An enhancement factor for concentrated load
Φ	Capacity reduction factor allowing for the effects of slenderness and eccentricity of loading
γ_M	Partial factor for a material property
ρ_n	Reduction factor (depending upon the edge restraint or stiffening of the wall, h/l and floor restraint)
ρ_t	Stiffness coefficient

References

- BRITISH STANDARDS INSTITUTION. BS EN 1996: Eurocode 6 – *Design of masonry structures*. BSI (4 parts). Including their NAs.
- ROBERTS, JJ & BROOKER, O. *How to design masonry structures to Eurocode 6: Introduction to Eurocode 6*. The Concrete Centre, 2013.
- ROBERTS, JJ & BROOKER, O. *How to design masonry structures to Eurocode 6: Lateral resistance*. The Concrete Centre. 2013.
- BRITISH STANDARDS INSTITUTION. BS EN 772–1: *Methods of test for masonry units – Determination of compressive strength*. BSI, 2011.
- BRITISH STANDARDS INSTITUTION. BS EN 1052–1: *Methods of test for masonry – Determination of compressive strength*. BSI, 1999.

Members of the steering group

Ali Arasteh, Brick Development Association; Owen Brooker, The Concrete Centre; Ken Fisher, International Masonry Society; Cliff Fudge, Aircrete Products Association; Charles Goodchild, The Concrete Centre; Gerry Pettit, Concrete Block Association; John Roberts, Consultant.

Members of the steering group for 2nd revision

Cliff Fudge, Aircrete Products Association; Charles Goodchild, The Concrete Centre; Simon Hay, Brick Development Association; Andy Littler, Concrete Block Association; John Roberts, Consultant; Guy Thompson, The Concrete Centre.

For more information on Eurocode 6 and other questions relating to the design, use and performance of concrete units, visit www.eurocode6.org

Acknowledgements

This publication was jointly sponsored by the following organisations:

- **Aircrete Products Association** - www.aircrete.co.uk
- **Brick Development Association** - www.brick.org.uk
- **Concrete Block Association** - www.cba-blocks.org.uk
- **MPA - Mortar Industry Association** - www.mortar.org.uk
- **MPA - The Concrete Centre** - www.concretecentre.com

Published by The Concrete Centre

Gillingham House, 38-44 Gillingham Street, London, SW1V 1HU
Tel: +44 (0)207 963 8000 | www.concretecentre.com